

Open End Commercial Bulker

Description: **36' x 8 1/2' Tandem / 40' x 8 1/2' Tandem / 42' x 8 1/2' Tandem**

DOEPKER
INDUSTRIES LTD.

Trailer Specifications

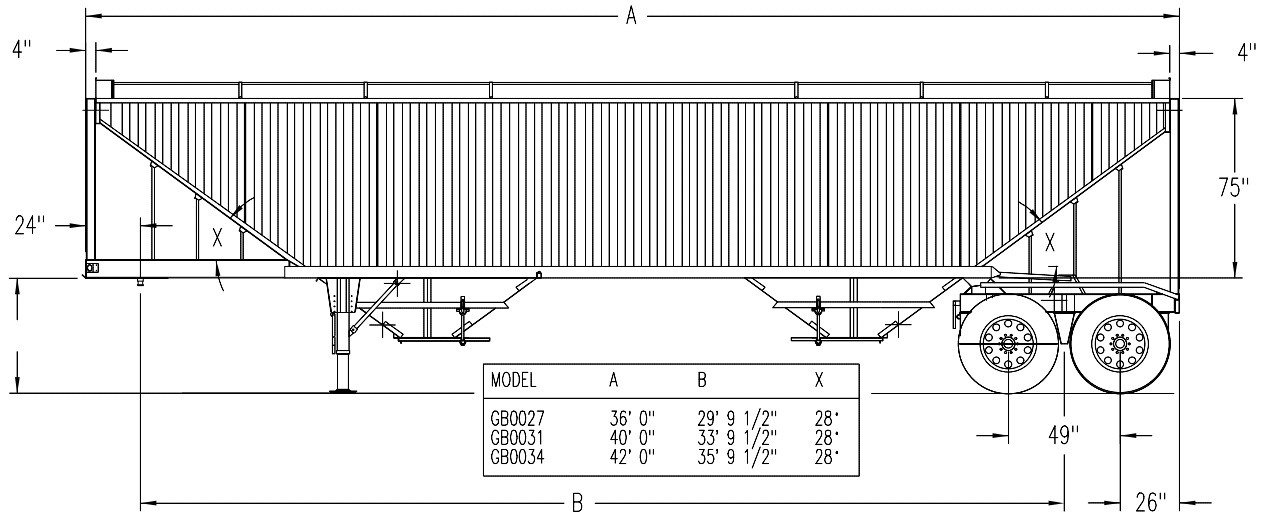

Standard Equipment

- Capacity
 - 36' - 1700 cu ft
 - 40' - 1900 cu ft
 - 42' - 2000 cu ft
 - Height
 - 132" to top of tarp hood with 75" O/A
 - Tare Weight
 - Including standard equipment approximately:
 - 36' - 10,100 lbs
 - 40' - 10,500 lbs
 - 42' - 10,900 lbs
 - General
 - Jost 2 speed landing gear
 - Jost king pin @ 24"
 - Aluminum catwalk and ladder
 - Ladders inside
 - Walls:
 - 16 gauge steel panel
 - 75" overall wall height
 - 4" vertical corrugations
 - Straight ends
 - Hoppers:
 - 14 gauge steel
 - Rack & pinion chutes
 - 16" x 24" openings
 - 22" ground clearance
 - Removable lid with self cleaning track
 - Slopes
 - 14 gauge aluminum slope sheet & end wall
 - As per model
 - Lighting
 - LED lights as per CMVSS
 - Side signal lights
 - Extra rear signal (red)
 - Finish
 - Fully sand blasted steel
 - Zinc Rich Primer on complete steel outside
 - PPG High Build Epoxy Primer inside and out
 - PPG Acrycote topcoat - two colors
 - Reflective tape
 - Duraguard
 - Tarp
 - Michel Side Winder
 - Long crank at rear
 - Welded aluminum hood
 - Choice of tarp color
 - Reinforcement on all arches
 - Tarp vents
 - Suspension
 - Intraax AA-230 air ride 23,000 lbs
 - Stemco seals
 - 16 1/2" x 7" P20-20 linings with dust shields
 - 30-30 spring brake
 - 2S1M anti-lock braking system
 - Auto slacks
 - Air system per CMVSS
 - Hubs, Rims & Tires
 - 10 stud Cast Unimount hub and drum
 - 22.5 - 10 hole steel unimount - powder coated white
 - 11R/22.5 tubeless radials B.F. Goodrich ST220
 - Protective Features
 - Mudflaps full width at landing gear
 - Mudflaps at back and chute mudflap
 - Stoneguard fenders at front of trailer
 - Aluminum checkerplate fenders at rear of trailer
 - Rear impact guard where required
- * Safety Certified